







# TREVIRA

**TREVIRA**  
hochfest

-  SILOS IN TESSUTO ORIGINALE "TREVIRA"
-  SILOS IN ORIGINAL "TREVIRA" FABRIC
-  SILOS EN TOILE ORIGINALE "TREVIRA"
-  ORIGINALE "TREVIRA"-SACKSILOS



**AGRITECH**<sup>®</sup>  
STORAGE AND MORE

# STR



**AGRITECH È LIETA DI PRESENTARE UNA GAMMA DI SILOS IN TESSUTO ORIGINALE “TREVIRA” PER LO STOCCAGGIO DI MANGIMI ZOOTECNICI E PRODOTTI INDUSTRIALI IN POLVERE ALL’INTERNO DEI CAPANNONI.**

I silos mod. STR sono costituiti da grandi sacchi in tessuto ad alta tenacità e lunga durevolezza, a 2 serie di tasche, sostenuti da una adeguata struttura in ferro zincato a caldo. Essi sono disponibili per capacità comprese fra 2 e 30 m<sup>3</sup>. Su richiesta vengono progettati silos di misure e capacità speciali. I silos mod. STR possono essere equipaggiati con accessori quali tubi in ferro zincato a caldo per il riempimento pneumatico e diversi pozzetti per lo scarico del prodotto.



**AGRITECH IS PROUD TO PRESENT A RANGE OF SILOS IN ORIGINAL “TREVIRA” FABRIC FOR THE INDOOR STORAGE OF COMPOUND FEEDS AND INDUSTRY BULK PRODUCTS IN POWDER.**

“Trevira” silos mod. STR are made of large, resistant and high-tenacity fabric bags with 2 range of folds, supported by heavy-duty frames in deep hot galvanized steel. They are available in a capacity range from 2 to 30 m<sup>3</sup> as a standard. Upon request, Agritech is in a position to project silos with special dimensions and capacities. Silos mod. STR can be equipped with pneumatic filling pipes in deep hot galvanized steel and different kinds of bottoms for the product discharge.



**AGRITECH A LE PLAISIR DE VOUS PRÉSENTER UNE GAMME DE SILOS EN TOILE ORIGINALE «TREVIRA» POUR DES STOCKAGE DES ALIMENTS DE BÉTAIL ET DES PRODUITS INDUSTRIELS EN POUDRE À L’INTÉRIEUR DES BÂTIMENTS.**

Les silos mod. «STR» sont composés par des grands sacs en toile à 2 séries de poches à haute résistance, soutenus par des solides charpentes en fer galvanisé à chaud. Ils sont disponibles en plusieurs capacités de 2 à 30 m<sup>3</sup> comme standard. Sur demande, Agritech peut concevoir des silos avec dimensions et capacités spéciales. Les silos mod. STR peuvent être équipés avec des tubes en fer galvanisé à chaud pour le remplissage pneumatique et avec différents boitards pour l'extraction.



**AGRITECH PRÄSENTIERT EIN SORTIMENT VON ORIGINALEN „TREVIRA“-SACKSILOS ZUR INNENLAGERUNG VON MEHLIGEM ODER PELLETIERTEM TIERFUTTER, GETREIDE UND DIVERSEN INDUSTRIEPRODUKTEN.**

Die Silos Mod. „STR“ bestehen aus großen, äußerst reißfesten und dauerhaften Säcken mit 2 Taschenreihen, die von einem robusten Gestell aus feuerverzinktem Stahl unterstützt sind. Sie sind in mehreren Kapazitäten zwischen 2 und 30 m<sup>3</sup> als Standard erhältlich. Agritech ist aber imstande, nach Kundenanfrage „Trevira“-Silos mit speziellen Abmessungen und Kapazitäten zu entwerfen. Die Silos Mod. „STR“ werden nach Wunsch mit feuerverzinkten Befüllrohren und diversen Bodenteilen zur Produktentnahme geliefert.

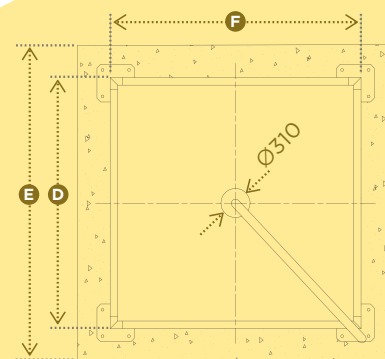
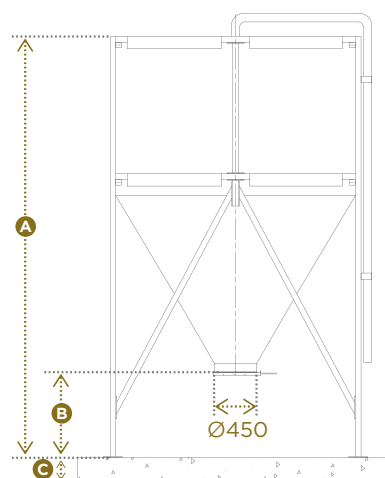

	M <sub>c</sub> *	TO. (0,6 TO./M <sup>3</sup> )	A (mm)	B (mm)	C (mm)	D (mm)	E (mm)
STR 02	2	1,2	2700	1280	900	200	2300
STR 04	4	2,4	3280	1580	900	200	2600
STR 06	6	3,6	3500	1900	900	200	3000
STR 08	8	4,8	3765	2100	900	250	3000
STR 10	10	6,0	3980	2300	900	250	3000
STR 12	12	7,2	4580	2320	900	250	3300
STR 15	15	9,0	4460	2620	900	300	3300
STR 17	17	10,2	4460	2660	900	300	3600
STR 25	25	15	5480	2960	900	350	4000
STR 30	30	18	6060	3000	900	350	4000

\* Volume calcolato con bocca di scarico diam. 450 mm. - The volume is calculated with an outlet of diam. 450 mm. - Le volume est calculé avec une sortie diam. 450 mm. - Der Rauminhalt ist aufgrund eines Auslaufes mit Durchm. 450 mm. gerechnet.



# SIT

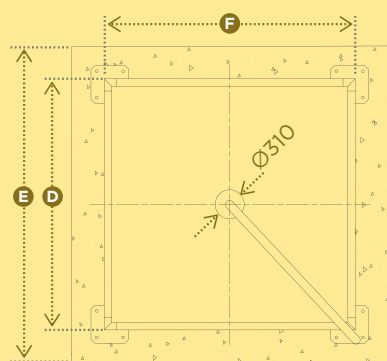
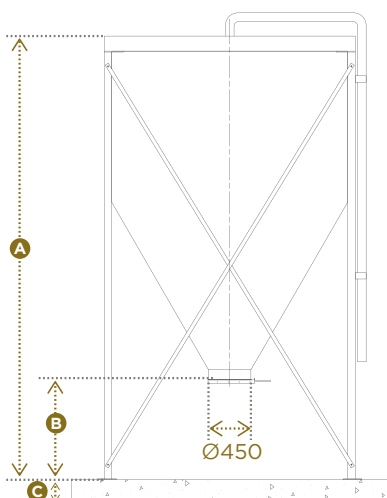

	Mc.*	TO. (0,6 TO./M <sup>3</sup> )	A (mm)	B (mm)	C (mm)	D (mm)	E (mm)
SIT O2	2	1,2	2670	1280	900	200	2300
SIT O4	4	2,4	3580	1600	900	200	2600
SIT O6	6	3,6	3690	1920	900	200	3000
SIT O8	8	4,8	4040	2120	900	250	3000
SIT 10	10	6,0	4100	2320	900	250	3000
SIT 12	12	7,2	4560	2360	900	250	3300
SIT 15	15	9,0	4700	2660	900	300	3300
SIT 17	17	10,2	5100	2660	900	300	3600

\* Volume calcolato con bocca di scarico diam. 450 mm. - The volume is calculated with an outlet of diam. 450 mm. - Le volume est calculé avec une sortie diam. 450 mm. - Der Rauminhalt ist aufgrund eines Auslaufes mit Durchm. 450 mm. gerechnet.



**AGRITECH PRODUCE ANCHE UNA SERIE DI SILOS IN TESSUTO “TREVIRA” PIÙ LEGGERI, MOD. SIT, PARTICOLARMENTE INDICATI PER LO STOCCAGGIO DI CEREALI E PRODOTTI INDUSTRIALI GRANULARI O PELLETATI.**

Essi sono costituiti da grandi sacchi in tessuto ad alta tenacità e lunga durezza, ad un'unica tasca, e sostenuti da una struttura leggera in ferro zincato a caldo. Essi sono disponibili per capacità comprese fra 2 e 17 m<sup>3</sup>. I silos mod. SIT possono essere equipaggiati con accessori quali tubi in ferro zincato a caldo per il riempimento pneumatico e diversi pozzetti per lo scarico del prodotto.



**AGRITECH ALSO PRODUCES A RANGE OF “LIGHTDUTY” “TREVIRA” FABRIC FABRIC SILOS MOD. SIT, THAT ARE PARTICULARLY SUITABLE FOR THE INDOOR STORAGE OF DRY CEREAL AND INDUSTRY BULK PRODUCTS IN GRAINS OR PELLETS.**

They are made of large, resistant and high-tenacity fabric bags in one single fold, supported by light-duty frames in deep hot galvanized steel. They are available in a capacity range from 2 to 17 m<sup>3</sup>. Silos mod. SIT can also be equipped with pneumatic filling pipes in deep hot galvanized steel and different kinds of bottoms for the product discharge.



**AGRITECH PRODUIT AUSSI UNE GAMME DE SILOS EN TOILE «TREVIRA» PLUS LÉGERS, MOD. SIT, APTES AU STOCKAGE DES ALIMENTS DE BÉTAIL ET DES PRODUITS INDUSTRIELS GRANULÉS OU PELLETÉS À L'INTÉRIEUR DES BÂTIMENTS.**

Ils sont composés par des grands sacs en toile, à une seule poche, à haute résistance, soutenus par des charpentes légers en fer galvanisé à chaud. Ils sont disponibles en plusieurs capacités de 2 à 17 m<sup>3</sup>. Les silos mod. SIT peuvent aussi être équipés avec des tubes en fer galvanisé à chaud pour le remplissage pneumatique et avec différents boîtards pour l'extraction.



**AGRITECH PRODUZIERT AUCH EINE „LEICHTERE“ VARIANTE VON „TREVIRA“-SACKSILOS, UND ZWAR MOD. SIT, ZUR INNENLAGERUNG VON TIERFUTTER UND DIVERSEN INDUSTRIEPRODUKTEN IN KÖRNIGER ODER PELLETIERTER FORM.**

Sie bestehen aus großen, äußerst reißfesten und dauerhaften Säcken aus einer einzigen Tasche, die von einem leichten Gestell aus feuerverzinktem Stahl unterstützt sind. Silos Mod. SIT sind in mehreren Kapazitäten zwischen 2 und 17 m<sup>3</sup> erhältlich. Auch Silos Mod. „SIT“ werden nach Wunsch mit feuerverzinkten Befüllrohren und diversen Bodenteilen zur Produktentnahme geliefert.





## MO32T



Serranda manuale quadrata  
mod. 32, diametro di connessione  
450 mm;

Square manual sliding gate mod.  
32, connection diam. 450 mm;

Trappe guillotine manuelle carrée  
mod. 32, diamètre de connexion  
450 mm;

Quadratischer Handschieber Mod.  
32, Einlaufdurchmesser 450 mm;

## MO33T

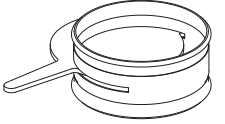

Serranda manuale rotonda mod.  
33, diametro di connessione  
250 mm;

Round manual sliding gate mod.  
33, connection diam. 250 mm;

Trappe manuelle ronde mod. 32,  
diamètre de connexion 250 mm;

Runder Handschieber Mod. 32,  
Einlaufdurchmesser 250 mm;

## MO34T

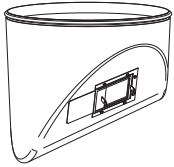

Pozzetto in vetroresina per coclea,  
mod. 34;

Auger bottom in fibreglass,  
mod. 34;

Fond de reprise en polyester pour  
vis sansfin, mod. 34;

GFK-Schneckenkasten, Mod. 34;

## MO56T

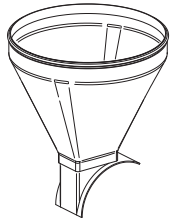

Raccordo in vetroresina per coclea  
flessibile, mod. 56;

Fibreglass connector for flex  
auger, mod. 56;

Raccord polyester pour vis souple,  
mod. 56;

GFK-Übergang auf Spiralförderer,  
Mod. 56;

AGRITECH SRL si riserva il diritto di apportare modifiche alle misure dei prodotti illustrati in questo catalogo, in qualunque momento, senza l'obbligo di preavviso. - AGRITECH SRL reserves the right to modify the dimensions of the products illustrated in this catalogue at any time and without prior notice. - AGRITECH SRL se réserve le droit de modifier à tout moment et sans préavis les dimensions des produits illustrés dans ce catalogue. - AGRITECH SRL behält sich das Recht vor, die Abmessungen der in diesem Katalog abgebildeten Produkte jederzeit und ohne vorherige Ankündigung zu ändern.

  
**AGRITECH**<sup>®</sup>  
STORAGE AND MORE



WE ONLY USE POWER  
FROM RENEWABLE  
SOURCES FOR  
OUR PRODUCTION



## Agritech s.r.l.

Via Rimembranze, 7  
25012 Calvisano (BS) Italy  
Tel. +39 030 99 68 222 r.a.

Fax +39 030 99 68 444  
commerce@agritech.it  
[www.agritech.it](http://www.agritech.it)



## DISTRIBUTOR

